

HZWS-X2 Transformer Oil Moisture Tester



Contents

I.Introduction	1
1.1 Instrument Description	1
1.2 Safety Instructions	1
II.Technical Specifications	1
2.1 Modes	1
2.2 Ambient temperature	2
2.3 Mains connection	2
2.4 Dimensions	2
III.Parts And Controls	3
3.1 Coulometer Part	3
3.2 Titration Vessel Part	4
3.3 Titration Vessel Setup	5
IV.Principle Of Coulometric KF Determinations	5
V.Determination	6
5.1 Cleaning	6
5.2 Reagents	6
5.3 Tips For Working With Water Standards	6
5.4 Recommendations For Practice	7
5.5 Optimal Working Conditions	8
5.6 Drift	8
5.7 Reagent Exchange	9
5.8 Indicator Electrode	9
VI.Manual Operation	9
VII. Packing List	14

I.Introduction

1.1 Instrument Description

The instrument of Coulometric Karl Fischer titrators is an used for Coulometric water determination according to Karl Fischer. The instrument is designed for usage as a titrator in analytical laboratories. Its main application field is volumetric titration. conform to the GB7600; IEC60422; ASTM D1533 standard.

The present instrument is suitable for processing chemicals and flammable samples. The usage of this titrators therefore requires that the user has basic knowledge and experience in the handling of toxic and caustic substances. Knowledge with respect to the application of the fire prevention measures prescribed for laboratories is also mandatory.

1.2 Safety Instructions

Warning: This instrument may only be operated in accordance with the specifications in this documentation.

Warning: An incorrect mains voltage can damage the instrument. Only operate this instrument with a mains voltage specified for it (see rearpanel of the instrument).

Warning: Never open the housing of the instrument. The instrument could be damaged by this. There is also a risk of serious injury if live components are touched. There are no parts inside the housing which can be serviced or replaced by the user.

II. Technical Specifications

2.1 Modes

Coulometric KF titration with automatic blank deduction **Endpoint indication**
Voltametric, AC indication **Iodine production** Pulse with variable current strength and length.

Current at the generator electrode: 100, 200, 400 mA

Titration speed max: 40 ug/s

Determination range 0 to 200 mg

Resolution 0.1 ug

Reproducibility Sample: Reagent manufacturer's standard. With 10 ug...1000 ug : ± 2 ug

With >1000 ug : 0.2% or better

Drift compensation automatic

Display Graphical LCD, 240 x 128 dots, LED back-lit

Printer Built-in thermal printer, Paper width 57 mm

Memory Data storage 500 results

Stirrer control coordinated with the titration process

RS232 interface computer connection

2.2 Ambient temperature

Nom. operation range 5 ... 40 °C

Storage – 20 ... 60 °C

Transport – 40 ... 60 °C

2.3 Mains connection

Voltage 110...220 V ± 10 %

Frequency 50 ... 60 Hz

Power consumption max. 30 W

2.4 Dimensions

Material of housing Steel

Material of display Glass(LCD)

Width 320 mm

Height 240 mm

Depth 150 mm

Weight 5 kg

III.Parts And Controls

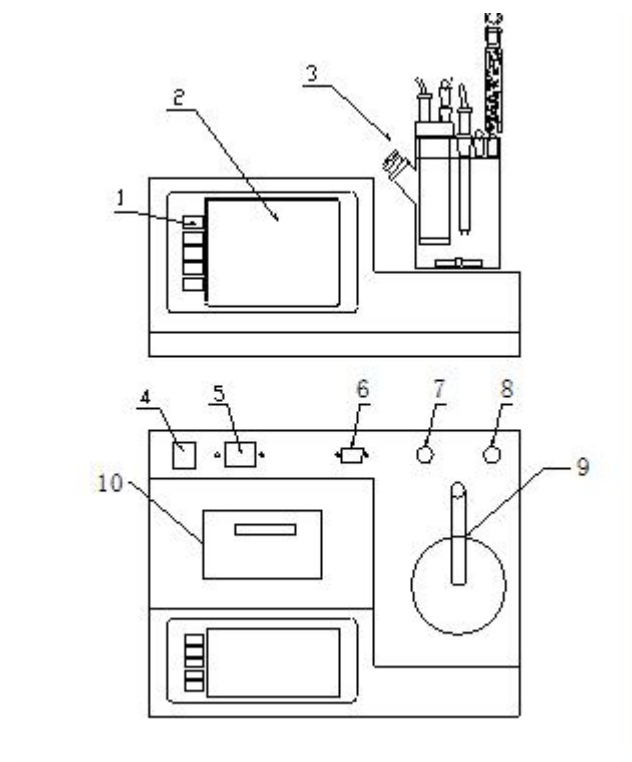

KF Coulometer

3.1 Coulometer Part

- 1 Keypad
- 2 Display
- 3 Titration vessel
- 4 Switch
- 5 Connection for power cable
- 6 USB interfaces
- 7 Connection of generator electrode
- 8 Connection of indicator electrode
- 9 Titration vessel bracket
- 10 Miniature printer

3.2 Titration Vessel Part

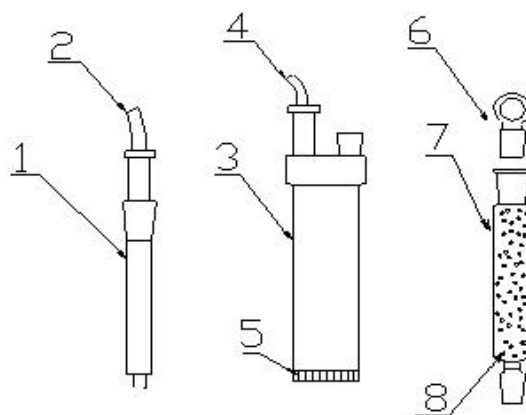

Electrolytic cell diagram

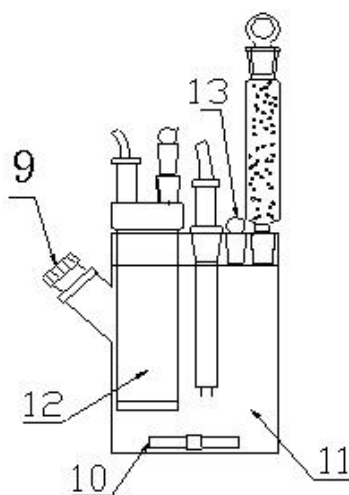

Electrolytic cell assembly diagram

- 1 indicator electrode
- 2 indicator electrode Wire
- 3 generator electrode
- 4 generator electrode Wire
- 5 diaphragm
- 6 Stopper
- 7 Drying tube for indicator electrode
- 8 Desiccant
- 9 Septum stopper
- 10 Stirring bar
- 11 Space of anode

12 Space of cathode

13 Stopper for Space of anode

3.3 Titration Vessel Setup

1. Attach titration vessel with holder to the support rod.
2. Place stirring bar in titration vessel.
3. Insert indicator electrode in the Right-hand joint opening.
4. Insert generator electrode in the Left- joint opening.
5. Fill the drying tube with molecular sieve and insert into generator electrode.
6. Place septum in the screw cap and screw this onto the titration vessel. Only tighten it enough to ensure that it is tight. (The septum should not be deformed!)
7. Fill titration vessel with 130-150 ml reagent.
8. Close last joint opening

IV.Principle Of Coulometric KF Determinations

The coulometric Karl Fischer titration is a version of the classical water determination method developed by Karl Fischer. The traditional method utilises a methanolic solution of iodine, sulphur dioxide and a base as buffer. Several reactions run in the titration of a water-containing sample and can be summarised by the following overall equation:



According to the above equation, I₂ reacts quantitatively with H₂O.

This chemical relation forms the basis of the water determination.

The classical Karl Fischer method has undergone constant development in the past years. This further development has involved not only refinement and automation of the reagent dispensing, but also improvement of the end point indication and the reagents. Despite the progress made, the classical, volumetric Karl Fischer method suffers from the disadvantage that the reagents are not completely stable resulting in the need to redetermine the titer at intervals.

In the coulometric Karl Fischer titration, the iodine needed is generated directly in the electrolyte by electrochemical means ("electronic buret"). The rigorously quantitative relationship between the electric charge and the amount of iodine generated is used for

high-precision dispensing of the iodine. As the coulometric Karl Fischer method is an absolute determination no titer need be determined. It is necessary only to ensure that the reaction which generates the iodine runs with 100% current efficiency. With the reagents available today this is always the case.

The end point is indicated voltametrically by applying an alternating current of constant strength to a double Pt electrode. This results in a voltage difference between the Pt wires of the indicator electrode which is drastically lowered in the presence of minimal quantities of free iodine. This fact is used to determine the end point of the titration.

V.Determination

5.1 Cleaning

The electrolyte solution can normally be exchanged without any special cleaning of the parts being necessary. If cleaning is necessary then care should be taken that the Pt grid of the generator electrode is not damaged.

Pollutants containing oil:

Clean with a solvent (e.g. hexane) and then rinse with ethanol.

Salt-like deposits:

Clean with water and then rinse with ethanol.

Dry all parts thoroughly after cleaning. A hot-air blower can be used for this. If the parts are dried in a drying oven take care that the temperature does not exceed 70°C (plastic components!).

5.2 Reagents

Reagents for coulometric water determination with generator electrodes with diaphragms consist of an anode solution (anolyte), which is filled into the titration vessel and a cathode solution (catholyte) which is filled into the generator electrode. Special reagents must be used for water determination in ketones and aldehydes; please refer to the reagent manufacturer's instructions.

5.3 Tips For Working With Water Standards

For validation of the instrument, as a fully integrated measuring system, commercial,

certified water standard solutions with water contents of 1.00 ± 0.003 mg/g and/or 0.10 ± 0.005 mg/g should be applied (The 1.0 mg/g Standard is easier to handle and therefore to prefer).

Recommended initial weight range:

Liquid standard 1.0 mg/g 0.2-2.0 g

Liquid standard 0.1 mg/g 0.5-1.5 g

5.4 Recommendations For Practice

For validation of the system very accurate handling is needed. To minimise possible measuring inaccuracies the sample preparation and handling should run accordingly to the following procedure:

1. Wear gloves (As always in KF Titration).
2. Take a fresh plastic syringe and open it.
3. Take a fresh ampoule of KF standard and shake it for 10 seconds.
4. Open the ampoule and suck 1 ml of the standard into the syringe.
5. Pull the piston of the syringe up to the end and shake the syringe for a few seconds, so that the inner part of the syringe is rinsed with standard and gets rid of water contamination.
6. Splash the used standard into a waste bottle.
7. Repeat the same procedure with another ml of the standard solution.
8. Suck the whole rest of the standard into your syringe. Thereafter, verify that there is no more solution in the needle by sucking a small amount of air into the syringe.
9. Clean the needle by wiping it with a soft tissue. Close the needle with the corresponding cap.
10. Place the syringe on the balance and press TARA.
11. As soon as the drift at your Coulometer is stable, you can take the syringe, press <Start> at the Coulometer and inject around 1 ml of the standard. This can be done in two different ways:
 - a. The standard is injected without dipping the needle. If a small drop keeps hanging at the needle, aspirate it back into the needle, before pulling the needle out of the septum.

b. The standard is injected directly under the surface of the KF solution. Furthermore, make sure that the standard doesn't splash on the wall of the vessel or on the electrode.

12. Close the syringe and put it back on the balance.

13. Read the indicated value off the balance and feed it at your Coulometer as sample size.

14. As soon as the determination has finished and the titration cell is conditioned again, you can start with the next determination.

5.5 Optimal Working Conditions

Instrument basic drift is reached within approx. 30 minutes. It is recommended that the titration vessel is carefully shaken several times during this time.

For precise determination of amounts of water below 100 μg it may also be an advantage to condition the instrument overnight before use.

If the instrument is switched off for a longer period of time with a filled titration vessel then a certain time is required for it to become dry again after it is switched on. During continuous operation the instrument should not be switched off overnight.

5.6 Drift

A constant drift of the order of about $\leq 4 \mu\text{g}/\text{min}$ is good. However, lower values are certainly possible. If higher, stable values occur then the results are normally still good as the drift can be compensated.

A drift which remains high may be caused by water-containing depots, in inaccessible locations inside the cell. In such cases a reduction in the value would be achieved by shaking the titration vessel.

Take care that no drops above the level of the liquid are formed in the titration vessel.

For generator electrodes with diaphragms shaking must not be so vigorous as to cause the catholyte and anolyte to become mixed with each other.

If even after shaking the drift remains too high over longer periods of time then the electrolyte solution must be exchanged.

When working with the oven a drift $\leq 10 \mu\text{g}/\text{min}$ is good. The drift depends on the gas flow (the smaller the gas flow the lower the drift).

5.7 Reagent Exchange

In the following cases the electrolyte solutions should be exchanged:

- When the titration vessel is too full.
- When the capacity of the reagent is exhausted.
- If the drift is too high and shaking the cell does not result in any improvement.

Removal of the used electrolyte solutions from the cell is most easily carried out by aspiration as it is not necessary to disassemble the cell.

If strong pollution occurs the cell can be rinsed with a suitable solvent which should also be aspirated off.

5.8 Indicator Electrode

A new indicator electrode may require a certain running-in period for the formation of the surface. This may cause unusually long titration times and measurement results which are too high. These phenomena vanish after a short period of use. In order to speed up the running-in of a new indicator electrode the Coulometer can be conditioned overnight, for example.

A polluted indicator electrode can be carefully cleaned with an abrasive cleansing agent After cleaning it should be rinsed with ethanol. The two Pt wires of the indicator electrode should be as parallel to one another as is possible. Check on insertion.

VI. Manual Operation

PowerOn the instrument will see the follow picture (Figure 1)

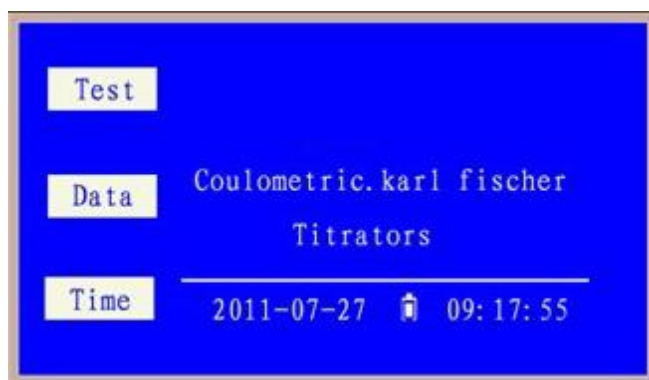

Figure 1

Press <Time> Key to adjust time function (Figure2)

Press <data> Key to history recode function (Figure3)

Press <Test> Key to test function (Figure4)



Figure 2

Press <Tab>,<Inc>,<Dec> Key select item and change data,

Press <Enter> Key save time

Press <Exit> exit to Figure 1

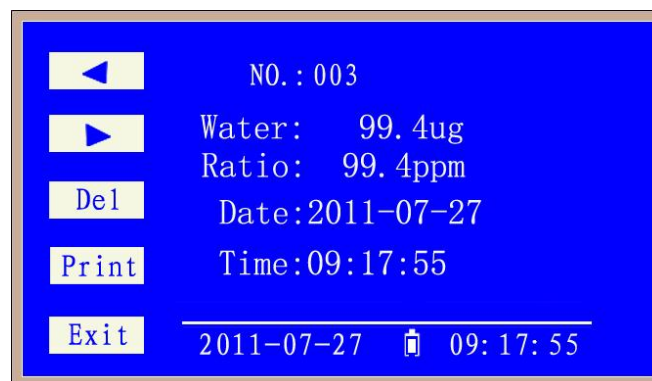

Figure 3

Press <◀>,<▶>,Key change page.

Press Key delete current data

Press <Print> print current data

Press <Exit> exit to Figure 1

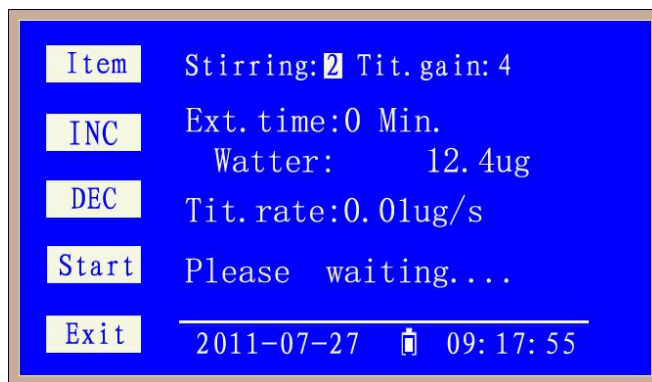

Figure 4

Pre-conditioning begins, i.e. the titration vessel is not dried. "Please waiting..." will display, instrument auto titrating extra water.

Until titration vessel is dried, then display Figure 5.

Press <Item> Key select item

Press <Inc>, <Dec> Key chang parameters.

Press <Exit> exit to Figure 1



Figure 5

Press <Item> Key select item

Press <Inc>, <Dec> Key chang parameters.

Press <Start> Key start testing when titration vessel is dried.

And display "addition samples" in Figure 6

Press <Exit> exit to Figure 1

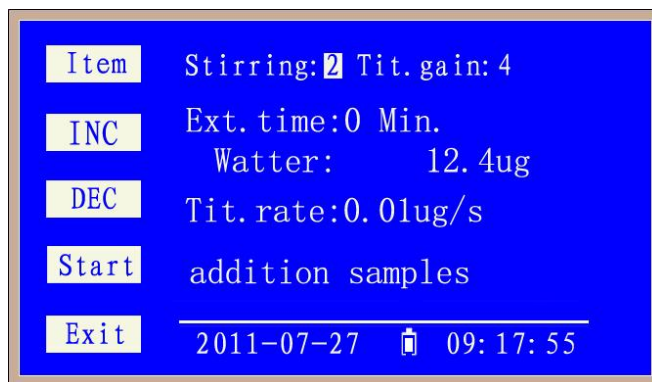

Figure 6

When user add samples into titration vessel, instrument auto titrating, And display “titrating...” Figure7

Press<Item>Key select item

Press<Inc>,<Dec> Key chang parameters.

Press <Exit> exit to Figure 1

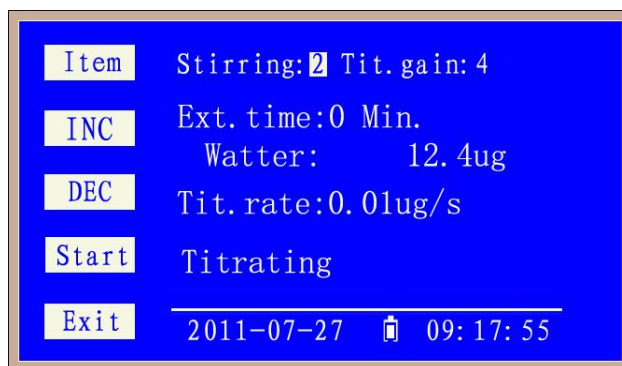

Figure 7

After the titration the result is displayed you can select the various formula to calculate result. such as Figure 8, Figure 9, Figure 10.

and The titration vessel is continuously kept dry.

1. Enter the density and volume of the sample, automatically calculate the mass of the sample and calculate the moisture content of the sample. The unit of moisture content is ppm. As shown in Figure 6-8;
2. Enter the sample volume, automatically calculate the moisture content of the sample, the unit of moisture content is mg/L. As shown in Figure 6-9;
3. Enter the quality of the sample and automatically calculate the moisture content of the sample. The unit of moisture content is ppm. As shown in Figure 6-10;

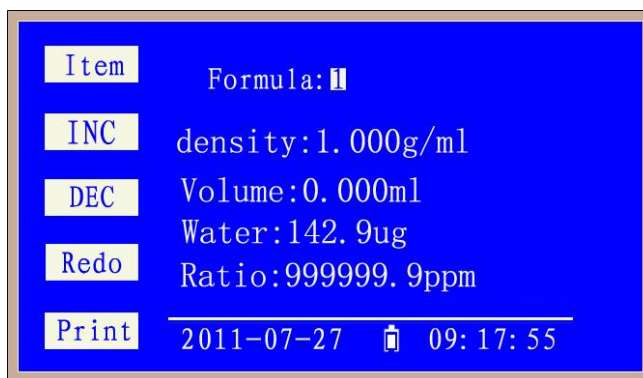

Figure 8

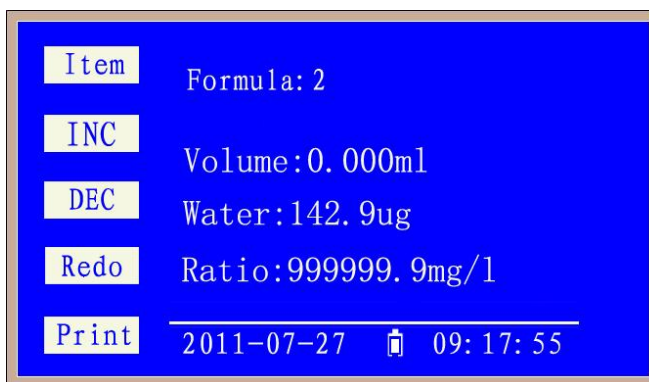

Figure 9

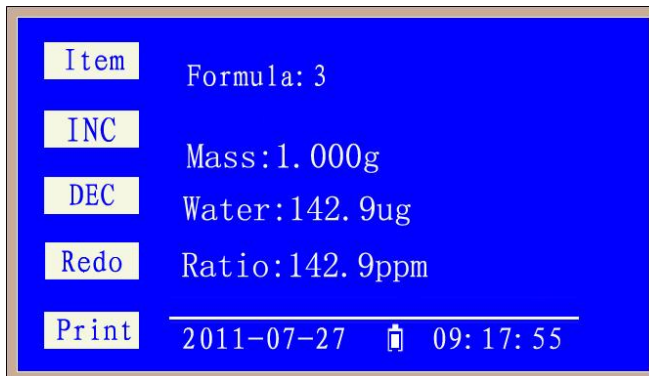

Figure 10

If you want to determine further samples press <Redo> again and inject the next sample....return Figure 5.

VII. Packing List

No.	Item	Qty
1	Main engine	1
2	Electrolysis pool	1
3	Electrolysis electrode	1
4	Measuring electrode	1
5	Drying tube	1
6	Sealing plug	4
7	Stirrer	2
8	Karl Fischer reagent	1
9	Allochroic silica gel	1
10	50 μ l micro injector	1
11	1ml injector	1
12	0.5 μ l micro injector	1
13	Vacuum grease	1
14	Silicone pad	10
15	Power line	1
16	Print paper	1